

版本	A/0	REV	REVISIONS REC	DATE

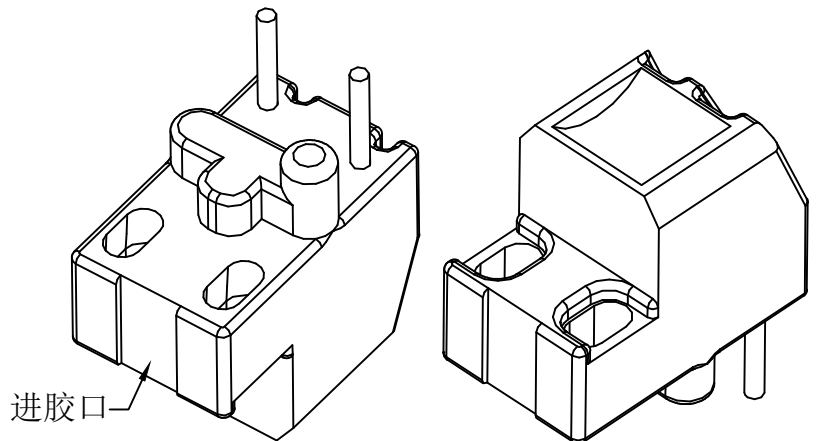
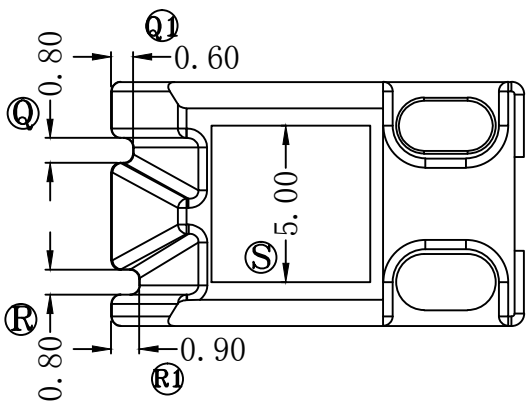
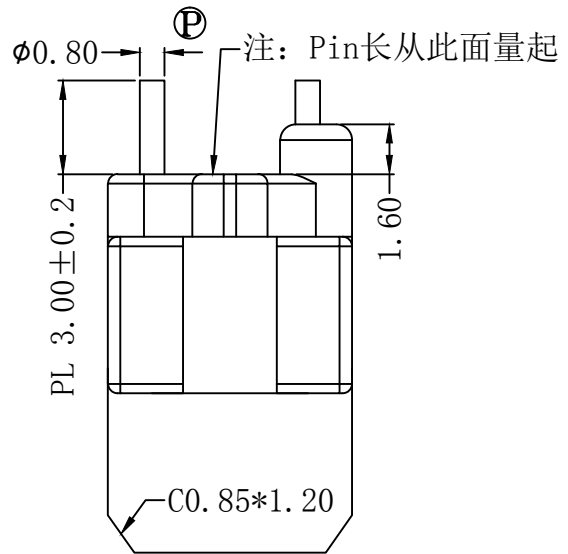
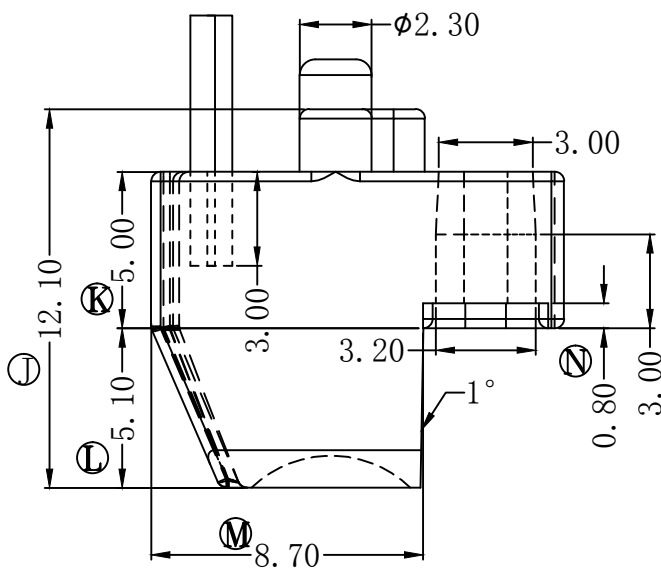
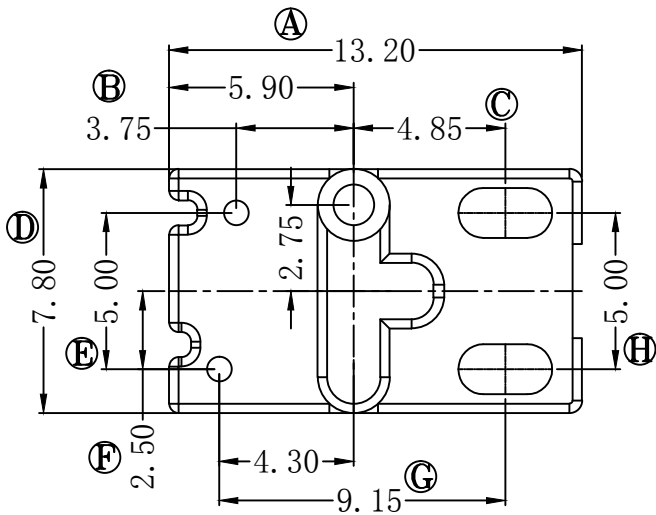

深圳市搏思康电子有限公司

SHENZHEN BOSCOM ELECTRONICS CO., LTD

ADDRESS	深圳市观澜街道石马径社区君新路 石三工业区146号
TELEPHONE	0755-28032969 28032970 28032971
FAX	0755-28032965

型号 MODEL NAME		产品编号 DRAWING NO	
8x12(2P) BASE		B-B109-2	
MATERIAL	T-375HF	PIN MATERIAL: CP WIRE	符合ROHS/HP要求 符合UL94V-0标准
SCALE	FIT		TOLERANCE
DRWING	20/03/2019	0 ≤ L ≤ 4 ± 0.10	
DESIGNED	庄永委	0 ≤ L ≤ 16 ± 0.20 壁厚: ± 0.10	
APPROVED		16以上 ± 0.30 PIN径: ± 0.05	