

版本	A/1	REV	REVISIONS REC	DATE
		A/1	①处原1.70改为2.50	2019.02.19
			①尺寸原5.10改为5.90	2019.02.19
			⑥尺寸原17.6改为18.4	2019.02.19

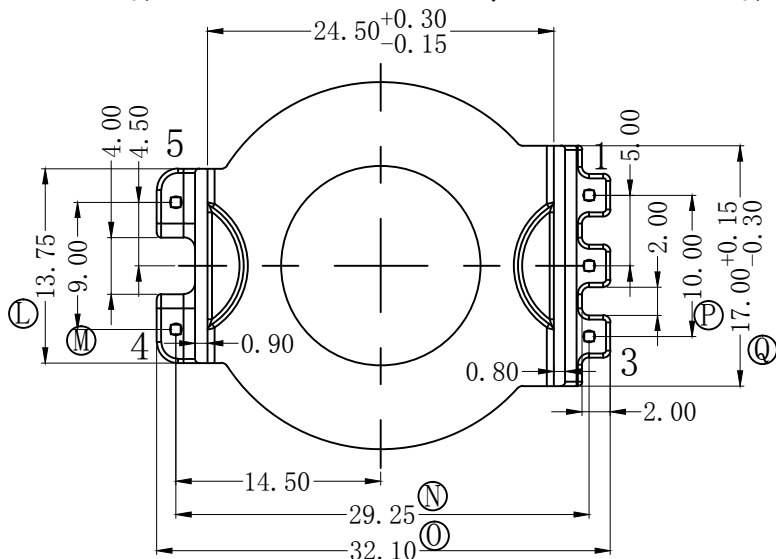

注:

1. 材质: PM-9630
2. 任意一点强度须1.8kg Min
3. 耐压要求: 4KV/1.5mA/1分钟
4. 焊锡温度: 450° ± 10° 3SEC
5. 焊锡前拉力: 2.0kg Min  
焊锡后拉力: 2.00kg Min

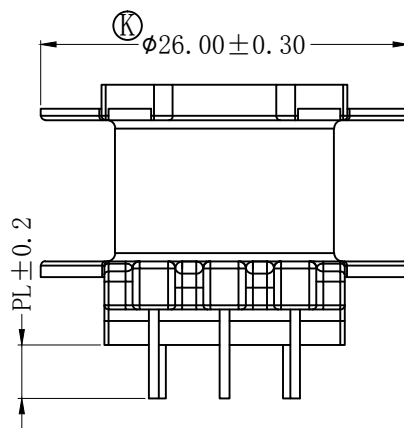
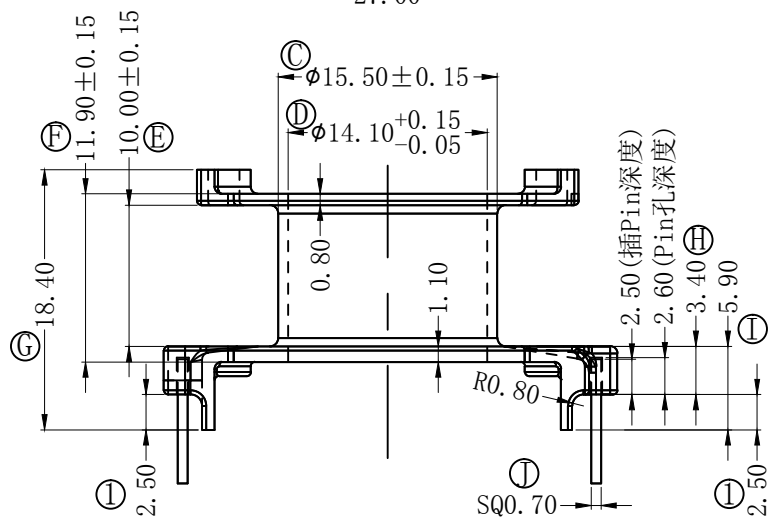
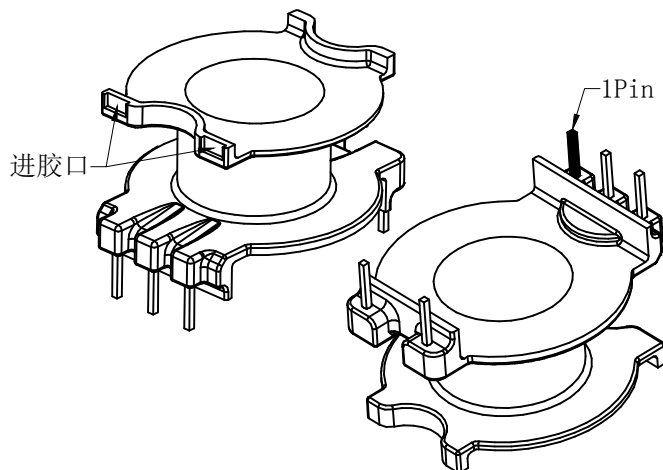
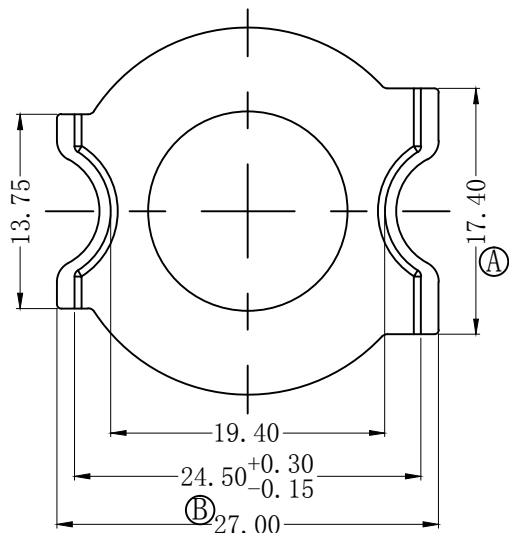

深圳市搏思康电子有限公司  
SHENZHEN BOSCOM ELECTRONICS CO.,LTD

ADDRESS	深圳市观澜街道石马径社区君新路石三工业区168号
TELEPHONE	0755-28032969 28032970 28032971
FAX	0755-28032965

型号 MODEL NAME		产品编号 DRAWING NO	
CC-33 (3+2P)		B-3345	
MATERIAL	PM-9630	PIN MATERIAL:	符合ROHS/HF要求
SCALE	FIT	CP WIRE	符合UL94V-0标准
DRWING	19/02/2019	TOLERANCE	
DESIGNED	庄永委	0<L<4 ±0.10	壁厚: ±0.10 PIN径: ±0.05
APPROVED		4≤L≤16 ±0.20	
		16以上 ±0.30	