

版本	A/O	REV	REVISIONS REC	DATE

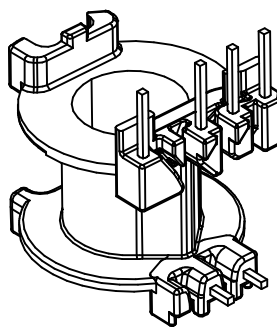

注:

1. 材质: PM-9630/BK
2. 耐压要求: 4KV/1.5mA/1分钟
3. 焊锡温度: $450^{\circ} \pm 10^{\circ}$ 3SEC
4. 1-4Pin焊前拉力: 2.0kg Min
1-4Pin焊后拉力: 2.5kg Min
5. 强度要求: 1.5kg Min
6. 模具状况: 量产模
7. Pin植入深度注意管控

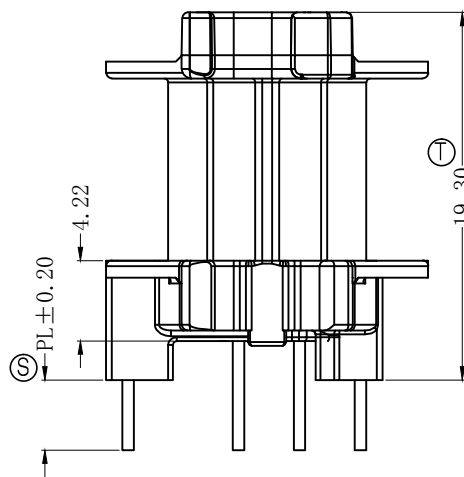
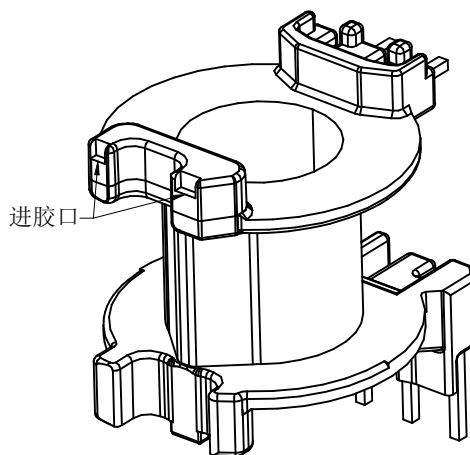
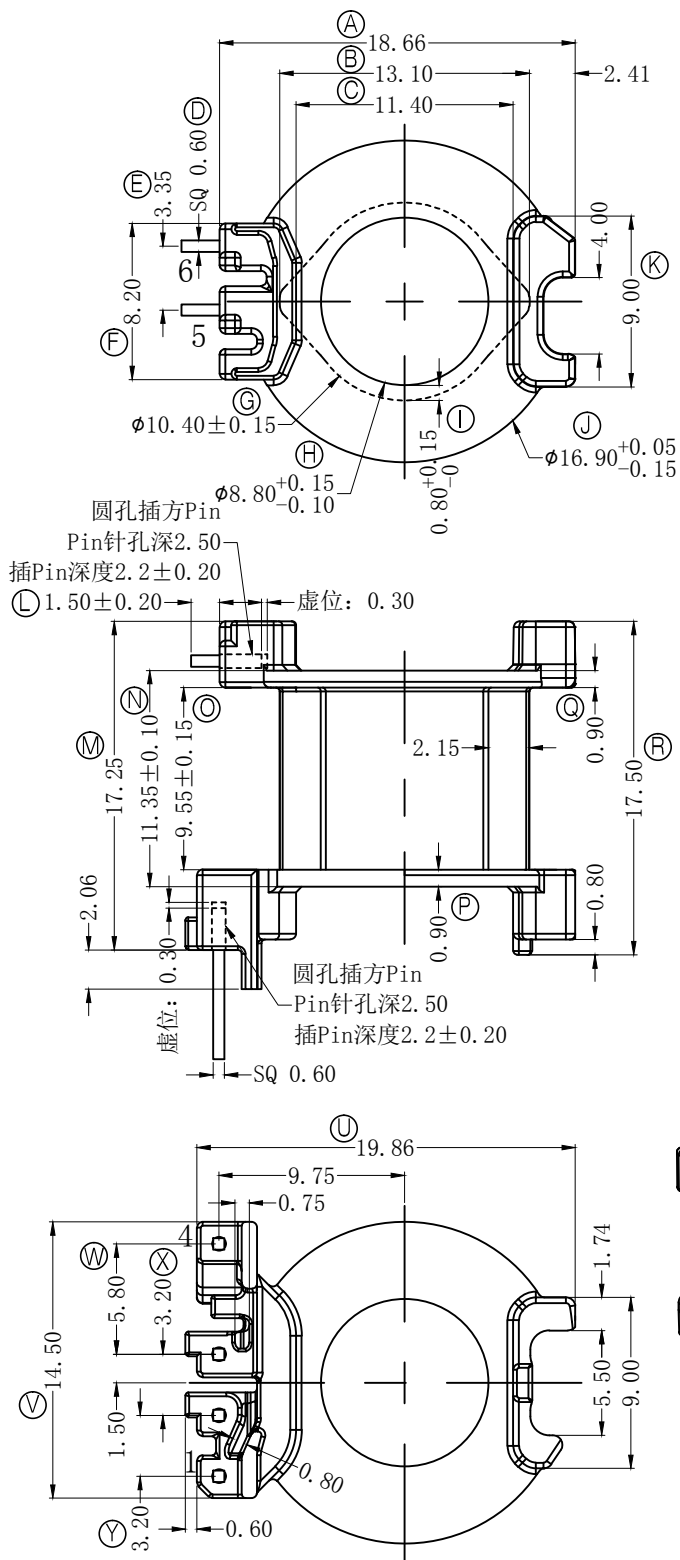

深圳市搏思康电子有限公司

SHENZHEN BOSCOM ELECTRONICS CO.,LTD

ADDRESS	深圳市观澜街道石马径社区君新路石三工业区146号
TELEPHONE	0755-28032969 28032970 28032971
FAX	0755-28032965

型号 MODEL NAME		产品编号 DRAWING NO	
RM-8.0 (4+2P)		B-0848	
MATERIAL	PM-9630	PIN MATERIAL:	符合ROHS/HF要求
SCALE	FIT	CP WIRE	符合UL94V-0标准
DRWING	22/08/2019	TOLERANCE	
DESIGNED	庄永委	0<L<4	± 0.10 壁厚: ± 0.10
APPROVED		4≤L≤16	± 0.20 PIN径: ± 0.05
		16以上	± 0.30