

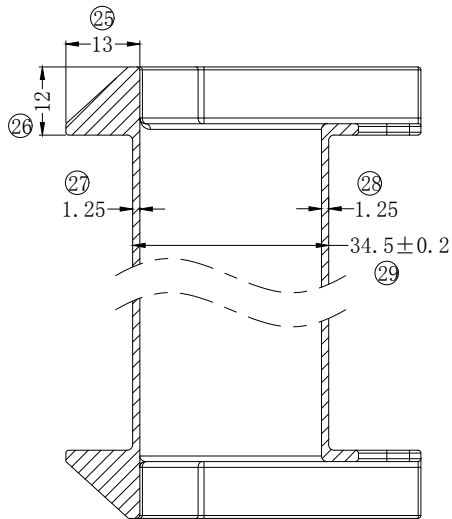

试做模

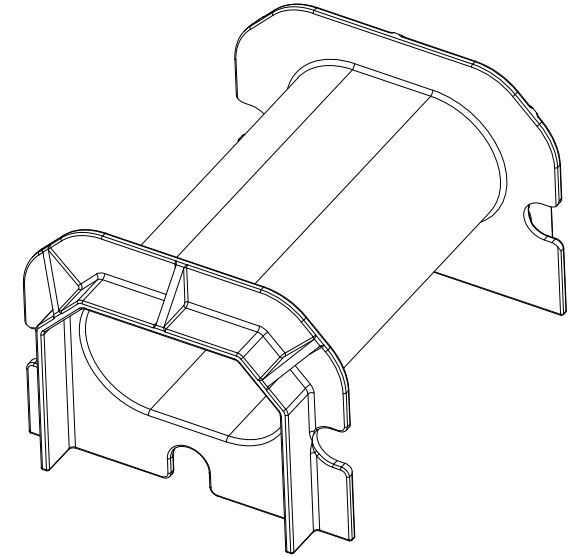
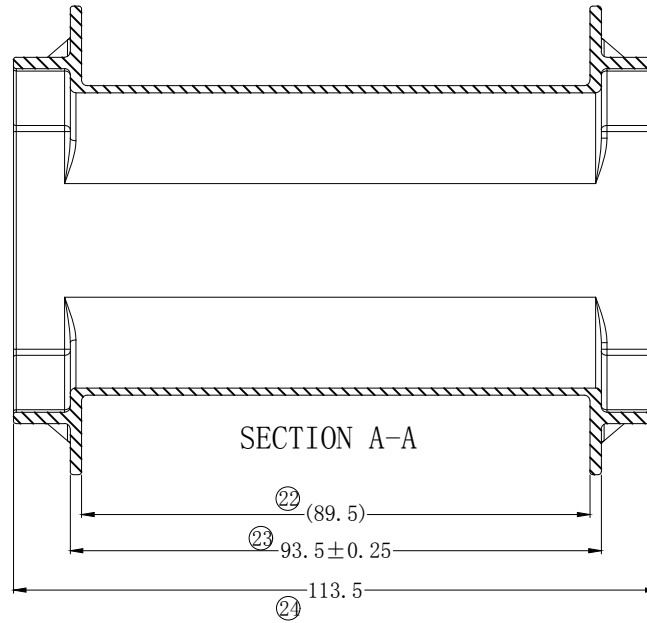
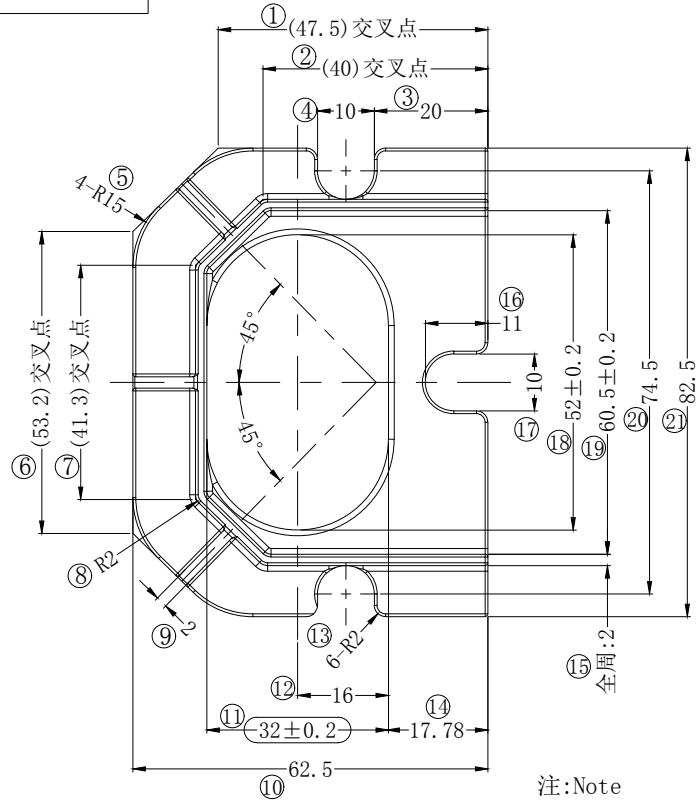

SECTION B-B

注:Note

- 1、未标示R角尺寸为0.5
Unless otherwise specified, The corner is made about R0.5
- 2、不允许使用脱模剂
Release agent is forbidden.
- 3、未指定的拔模角度使用公差内最小角度
Unless otherwise specified, An omission incline is assumed to be the most small by Clearance
- 4、删除显著的缩痕、毛刺、熔合线、充填不足。
Delete remarkable sink mark and burr, weld, short mold.
- 5、标示“

客户料号: C-Z9-06552

深圳市搏思康电子有限公司 SHENZHEN BOSCOM ELECTRONICS CO., LTD		型号 MODEL NAME	产品编号 DRAWING NO	
ADDRESS: 深圳市龙华区观澜街道牛湖社区君新路164号		B B	B-B248	
TELEPHONE: 0755-29673660 29673519			MATERIAL	PIN
广东搏思远科技有限公司 Guangdong Bosyuan Technology Co., Ltd		FR530BK	MATERIAL	
		SCALE	TOLERANCE	
		DRWING	0<L≤4 ±0.08	
ADDRESS: 河源市高新区富民工业园A区联体厂房A栋南栋		DESIGNED	4<L≤20 ±0.10	
TELEPHONE: 0762-2820657 2820658 2820659 2820660		APPROVED	20<L≤50 ±0.15	
			50<L≤200 ±0.25	