

版本:	A/0	REV.	REVISIONS REC.	DATE

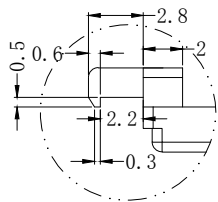

A

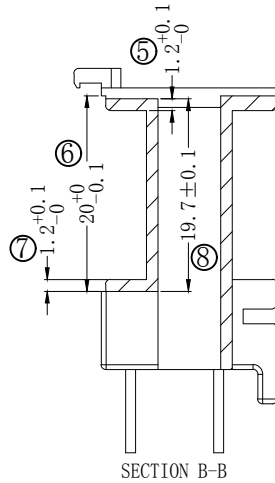
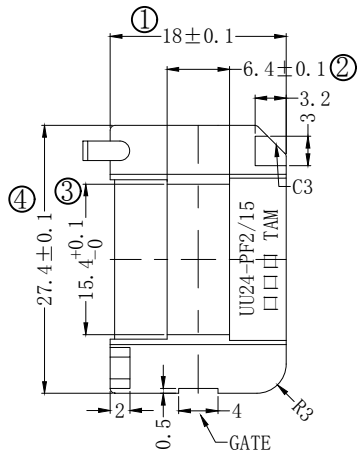

SECTION B-B

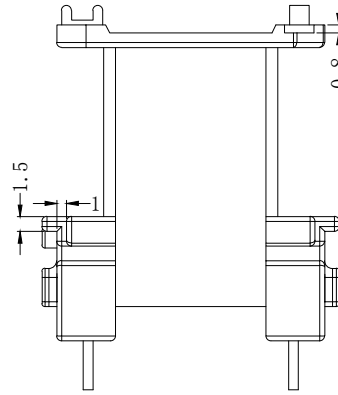
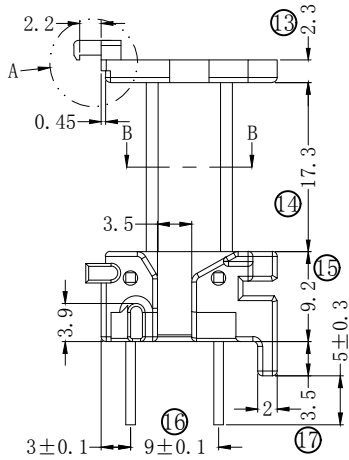
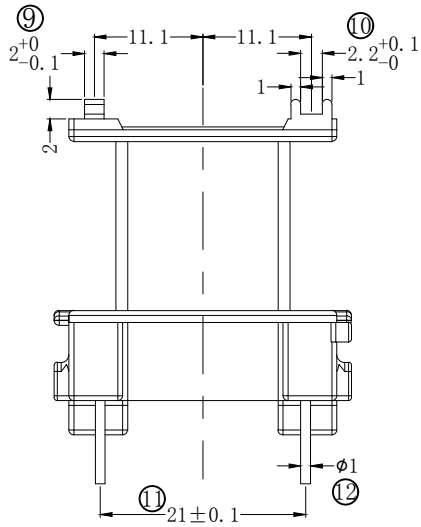
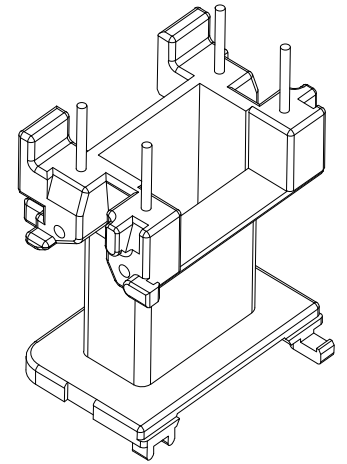
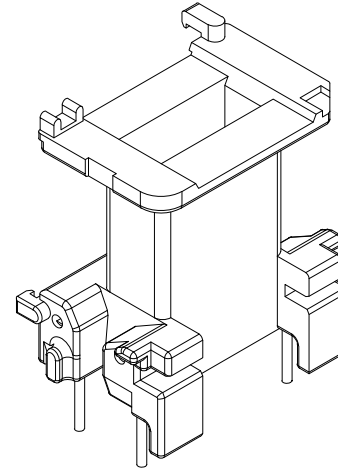

SECTION A-A

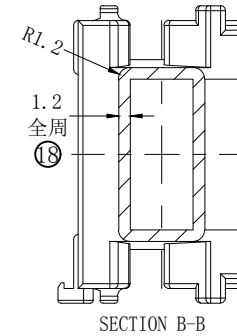
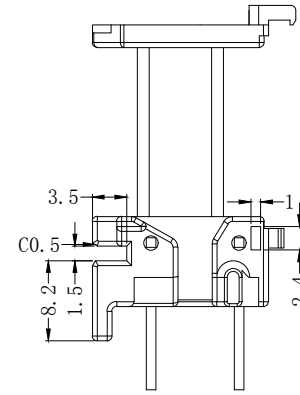

SECTION B-B

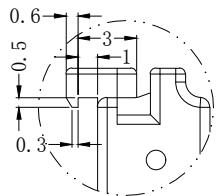

B

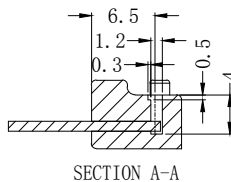
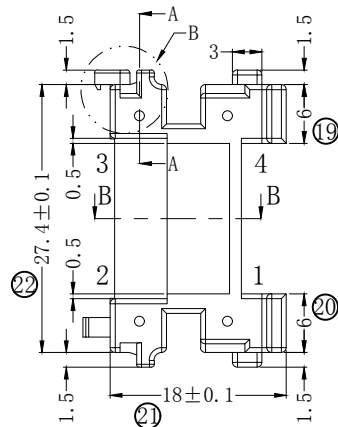

注:

1. 针脚压拔强度: 30N以上

客户料号: E-B1-11435A

深圳市搏思康电子有限公司 SHENZHEN BOSCOM ELECTRONICS CO.,LTD ADDRESS: 深圳市龙华区观澜街道牛湖社区君新路164号 TELEPHONE: 0755-29673660 29673519		型号 MODEL NAME BB UU24-PF2/15	产品编号 DRAWING NO B-2410												
广东搏思远科技有限公司 Guangdong Bosyuan Technology Co.,Ltd ADDRESS: 河源市高新区富民工业园A区联体厂房A栋南栋 TELEPHONE: 0762-2820657 2820658 2820659 2820660		MATERIAL FR-530 NC SCALE FIT DRWING 04/03/2022 DESIGNED 庄永委 APPROVED	<table border="1"> <tr> <th>PIN MATERIAL</th> <th>CP WIRE</th> </tr> <tr> <td colspan="2">TOLERANCE</td> </tr> <tr> <td>0<L≤4</td> <td>±0.08</td> </tr> <tr> <td>4<L≤20</td> <td>±0.10</td> </tr> <tr> <td>20<L≤50</td> <td>±0.15</td> </tr> <tr> <td>50<L≤200</td> <td>±0.25</td> </tr> </table>	PIN MATERIAL	CP WIRE	TOLERANCE		0<L≤4	±0.08	4<L≤20	±0.10	20<L≤50	±0.15	50<L≤200	±0.25
PIN MATERIAL	CP WIRE														
TOLERANCE															
0<L≤4	±0.08														
4<L≤20	±0.10														
20<L≤50	±0.15														
50<L≤200	±0.25														